



COMMITTEES OF COUNCIL
AGENDA
Regular Meeting

Mayor Mary Robichaux
Councilmember Sarah Beeson
Councilmember Eren Brumley
Councilmember Christine Hall
Councilmember Jennifer Phillippi
Councilmember Allen Sells
Councilmember Chris Zack
City Administrator Randy Knighton

Tuesday, April 28, 2026

5:00 PM

City Hall - Room 220

CALL TO ORDER / ROLL CALL

Approval of the Minutes

1. Approval of the Committee Meeting Minutes - April 28, 2026.

Regular Agenda

2. Consideration Of Approval of a Retaining Wall over 6 feet for First Baptist Church Roswell
Presented by Jeannie Peyton, Planning and Zoning Director
3. Consideration to pursue a grant from the Federal Highway Administration (FHWA) from the Safe Streets and Roads for All (SS4A) program
Presented by Andy Phlegar, Director of Transportation
4. Consideration of a resolution to submit a Local Road Assistance Administration (LRA) project list for FY 2026 to the Georgia Department of Transportation (GDOT) and to accept the GDOT LRA funds with a budget amendment in the amount of \$1,221,801.94.
Presented by Andy Phlegar, Director of Transportation
5. Consideration to award a Task Order Chatfield Contracting, Inc. for the Farm Trace Stormwater Construction Project in an amount not to exceed \$380,229.74
Presented by Brian Watson, Director of Environmental/Public Works

6. Consideration to award a Task Order with Utility Asset Management for the Holcomb Woods Parkway Stormwater Pipe Lining Project in an amount not to exceed \$88,405

Presented by Brian Watson, Director of Environmental/Public Works

Adjournment



City of Roswell
Committees of Council
AGENDA ITEM REPORT

ID # - 10420

MEETING DATE: April 28, 2026
DEPARTMENT: Administration
ITEM TYPE: Agenda Vote

Approval of the Committee Meeting Minutes - April 28, 2026.

Regular Agenda

2. Consideration of a Request authorization for the Mayor and/or the City Administrator to sign a renewal contract with Arthur J. Gallagher Risk Management Services, LLC for property, casualty, and management liability insurance in an amount of \$1,339,397.

RESULT: APPROVED TO MOVE TO MAYOR AND COUNCIL [UNANIMOUS]

Next: 4/27/2026 7:00 PM

MOVER: Jennifer Phillippi, Councilmember

SECONDER: Eren Brumley, Councilmember

IN FAVOR: Robichaux, Beeson, Hall, Zack, Phillippi, Brumley, Sells

3. Consideration to approve Budget Amendment 21335101-04-27-26 in the amount of \$36,225 for the configuration of Emergency Medical Services (EMS) response bags and the purchase of Life Pack 1000 Automated External Defibrillator (AEDs) with Naloxone

RESULT: APPROVED TO MOVE TO MAYOR AND COUNCIL [UNANIMOUS]

Next: 4/27/2026 7:00 PM

MOVER: Sarah Beeson, Councilmember

SECONDER: Mary Robichaux, Mayor

IN FAVOR: Robichaux, Beeson, Hall, Zack, Phillippi, Brumley, Sells

4. Consideration of a text amendment to Articles 24.6, Adoption of Roswell Dredging Assistance Policy, Section 24.6.1 - Dredging Assistance Policy of the City of Roswell Code of Ordinances.

RESULT: APPROVED TO MOVE TO MAYOR AND COUNCIL [UNANIMOUS]

Next: 4/27/2026 7:00 PM

MOVER: Christine Hall, Councilmember

SECONDER: Allen Sells, Councilmember

IN FAVOR: Robichaux, Beeson, Hall, Zack, Phillippi, Brumley, Sells

5. Consideration of a resolution to update Sanitation/Solid Waste Fees to include a "House/Garage Door" service fee for residents

RESULT: APPROVED TO MOVE TO MAYOR AND COUNCIL [UNANIMOUS]

Next: 4/27/2026 7:00 PM

MOVER: Allen Sells, Councilmember

SECONDER: Chris Zack, Councilmember

IN FAVOR: Robichaux, Beeson, Hall, Zack, Phillippi, Brumley, Sells

6. Consideration Of Approval of a Retaining Wall over 6 feet for Fellowship Christian School

RESULT: APPROVED TO MOVE TO MAYOR AND COUNCIL [UNANIMOUS]

Next: 4/27/2026 7:00 PM

MOVER: Sarah Beeson, Councilmember

SECONDER: Mary Robichaux, Mayor

IN FAVOR: Robichaux, Beeson, Hall, Zack, Phillippi, Brumley, Sells

7. Discussion of the TSPLOST 3 Project List

RESULT: DISCUSSED

8. Discussion of the Riverside Park Sprayground being converted from a flow-through water system to a recirculating water system.

A motion was made by Councilmember Sells to move forward with the project as it exists and begin construction as quickly as possible. Councilmember Hall seconded. Councilmember Beeson modified the motion to approve moving this item forward as currently planned and going back into construction with the understanding that future options will be explored for potential modifications at a later date to support water conservation. Councilmember Hall seconded the amended motion.

RESULT: APPROVED [5 TO 2]

MOVER: Allen Sells, Councilmember

SECONDER: Christine Hall, Councilmember

IN FAVOR: Beeson, Hall, Zack, Phillippi, Sells

OPPOSED: Mary Robichaux, Eren Brumley

Adjournment

There being no further comments or discussion the meeting was adjourned at 7:20 PM



City of Roswell
Committees of Council
AGENDA ITEM REPORT

ID # - 10399

MEETING DATE: April 28, 2026
DEPARTMENT: Community Development
ITEM TYPE: Agenda Vote

Consideration Of Approval of a Retaining Wall over 6 feet for First Baptist Church Roswell

Action Required:

Agenda vote

Description:

As part of pipe replacement project, First Baptist Church of Roswell is requesting approval for a concrete retaining wall with a maximum height of 12 feet. This cast in place retaining wall will serve as a headwall for a stormwater drainage pipe.

Financial Impact:

N/A

Comments:

See attached



Memo

To: Mayor and City Council

From: Jeannie Peyton, Planning & Zoning Director

Date: April 23, 2026

Subject: Retaining Wall at First Baptist Roswell
ZMCC-0326-000006
 710 Mimosa Blvd

Enclosed, please find the plans for the application for a retaining wall over six (6) feet. All proposed retaining walls equal to or greater than 6 feet in height require review and approval by the Mayor and City Council.

As part of their planned pipe replacement project, First Baptist Church of Roswell is constructing a cast-in-place concrete headwall at the bottom of the sloped area behind the church. A headwall meets the definition of a “retaining wall” therefore, this project meets the criteria to be subject to Mayor and Council review and approval. At its highest point, the wall is approximately 12 feet in height and tapers to 2 feet on each end. The total length of the U-shaped wall is approximately 62.4 feet.

The wall is not visible from the public right-of-way. However, it is visible from the City owned property, Mimosa Hall.

If the wall is approved by Mayor and Council, the appearance of the wall will warrant approval through the administrative HPC process, which requires the wall to have a brick or stone “look” material.

The Community Development Department recommends approval of the retaining wall request.

38 Hill Street, Roswell, GA 30075
www.roswellgov.com



Aerial View



Approximate location of headwall

38 Hill Street, Roswell, GA 30075
www.roswellgov.com

Attachment: ZMCC-0326-000006 Memo-First Baptist Church Retaining Wall (First Baptist Church Roswell Retaining Wall)

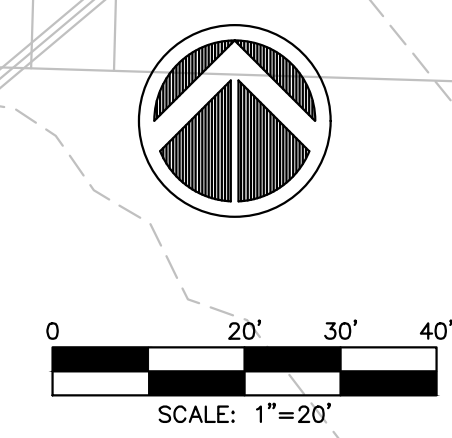
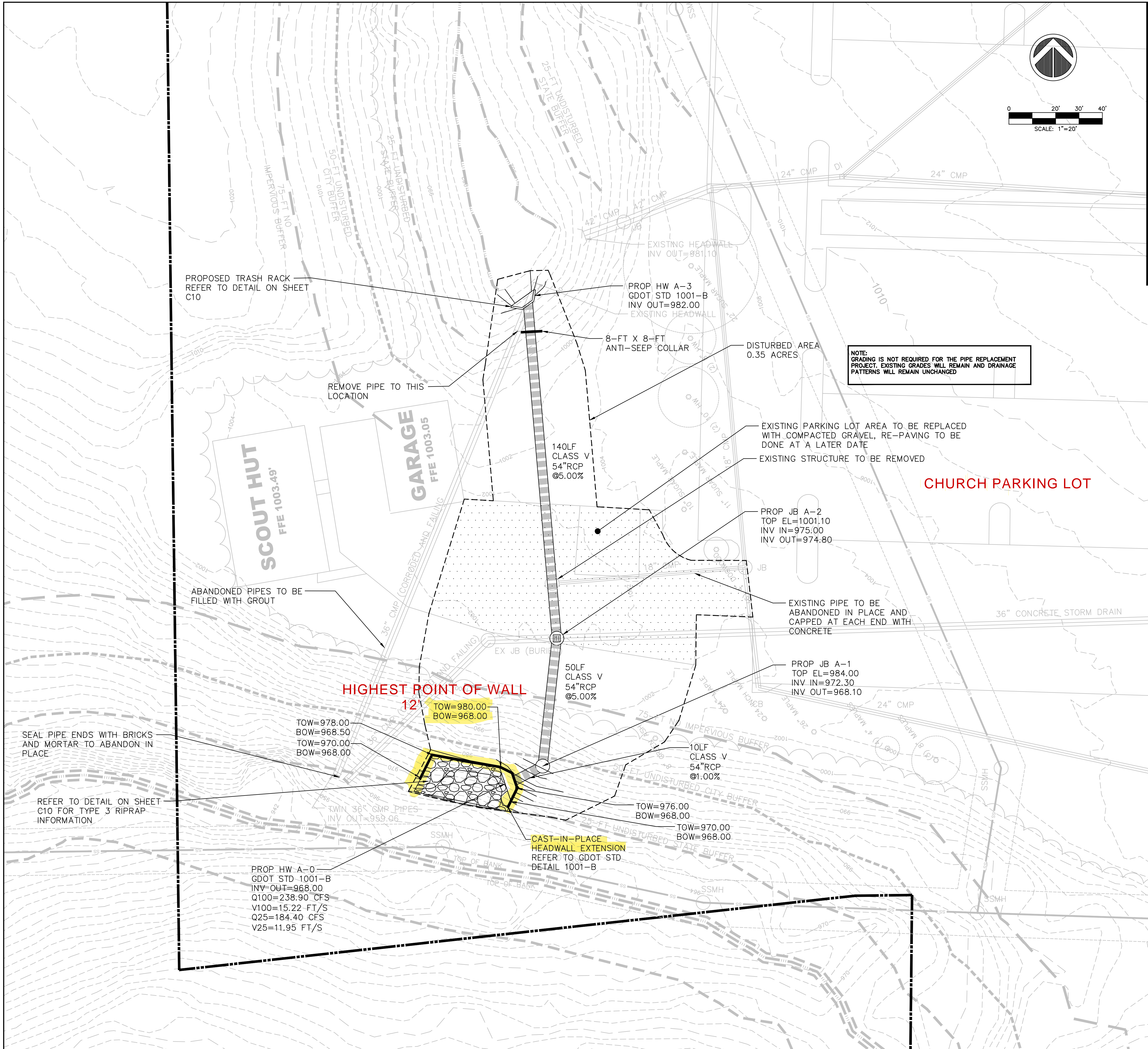

VICINITY MAP
N.T.S.

GRADING LEGEND

- EXISTING 2' CONTOUR
- EXISTING 10' CONTOUR
- FUTURE 1' CONTOUR
- FUTURE 5' CONTOUR
- EXISTING PROPERTY LINE
- EXISTING RIGHT-OF-WAY
- EXISTING SETBACK LINE
- FUTURE RIGHT-OF-WAY
- FUTURE SETBACK LINE
- FUTURE PROPERTY LINE
- GRADE ELEVATION
- X 980.00 STORM SEWER LINE
- RETAINING WALL
- CONCRETE HEADWALL
- JUNCTION BOX
- PRECAST CATCH BASIN
- AREA INLET
- GRATE INLET
- DETENTION BASIN OUTFALL STRUCTURE
- REINFORCED SLOPE (0.5:1)
- SLOPE ARROW
- HP/LP GRADE BREAK LINE

NOTE: 72 HOURS OF NOTICE IS REQUIRED TO GEORGIA 811 UTILITY PROTECTION CENTER BEFORE ANY LAND DISTURBANCE ACTIVITIES CAN BEGIN

NOTE: ADDITIONAL EROSION CONTROL DEVICES MAY BE REQUIRED BASED ON THE EXISTING SITE CONDITIONS IF DEEMED NECESSARY BY THE ON-SITE INSPECTOR

NOTE: CONTACT THE COMMUNITY DEVELOPMENT DEPARTMENT AT 770-641-3780 TO SCHEDULE A PRE-CONSTRUCTION MEETING WITH THE SITE INSPECTOR PRIOR TO ANY DISTURBANCE

NOTE: THE PLACEMENT OF DUMPSTERS AND THE PARKING OF AUTOMOBILES IS PROHIBITED IN THE RIGHT-OF-WAY.

NOTE: THIS SITE IS NOT LOCATED WITHIN A ZONE [A, AE, SHADED ZONE X] AS DEFINED BY F.I.R.M COMMUNITY FIRM PANEL 13121C0063F, DATED 9/18/2013 FOR UNINCORPORATED FULTON COUNTY, GEORGIA.

811 NOTE:
THE CONTRACTOR/INSTALLER SHALL ADHERE TO THE GEORGIA UTILITIES PROTECTION CENTER "GEORGIA 811 CALL BEFORE YOU DIG" LAW BY CALLING THE UNDERGROUND PROTECTION CENTER AT 1.800.282.7411 OR 811 48 HOURS PRIOR TO BEGINNING ANY GROUND DISTURBING ACTIVITIES.



ARCHITECTURE
CIVIL ENGINEERING
PROJECT MANAGEMENT
MASS DESIGN
WWW.MASSDESIGN.US

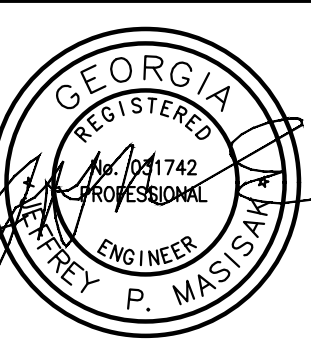

MASS DESIGN
3417 CANTON ROAD, SUITE 801
MARIETTA, GEORGIA 30066
PHONE: 404-850-7750
Copyright © 2024

PARKING LOT PIPE REPLACEMENT
710 MIMOSA BOULEVARD ROSWELL, GA 30075
PREPARED FOR:
FIRST BAPTIST ROSWELL
CITY OF ROSWELL
FULTON COUNTY, GEORGIA

TAX MAP ID: 12-1912-0384-001-4

REVISIONS	DESCRIPTION

PIPE REPLACEMENT PLAN	
PROJECT NUMBER:	25-0035
DATE:	JUNE 16, 2025
C04	



City of Roswell
Committees of Council
AGENDA ITEM REPORT

ID # - 10409

MEETING DATE: April 28, 2026
DEPARTMENT: Transportation
ITEM TYPE: Agenda Vote

Consideration to pursue a grant from the Federal Highway Administration (FHWA) from the Safe Streets and Roads for All (SS4A) program

Action Required:

Agenda Vote

Description:

In late 2023 the City of Roswell was awarded a \$200,000 Safe Streets and Roads for All (SS4A) Grant from the U.S. Department of Transportation (USDOT) to complete a Citywide Safety Action Plan. Following approval of the Safety Action Plan, the City may apply for a SS4A Implementation grant to fund projects and strategies identified in the Safety Action Plan to address roadway safety issues.

Implementation grants range from \$2,500,000 to \$25,000,000 and require a 20% locally funded match. The city would need to provide \$500,000 to \$5,000,000 in the FY2027 budget for the local match.

Staff recommends pursuing an implementation grant to fund a traffic calming treatment on Mimosa Boulevard and install multi-use trails on Mimosa Boulevard and Warsaw Road. These were two of the three highest scoring roadways in the Citywide Safety Action Plan.

Financial Impact:

This item requires a 20% local match, budget will be requested in FY 2027.

Comments:

N/A



City of Roswell
Committees of Council
AGENDA ITEM REPORT

ID # - 10427

MEETING DATE: April 28, 2026
DEPARTMENT: Transportation
ITEM TYPE: Agenda Vote

Consideration of a resolution to submit a Local Road Assistance Administration (LRA) project list for FY 2026 to the Georgia Department of Transportation (GDOT) and to accept the GDOT LRA funds with a budget amendment in the amount of \$1,221,801.94.

Action Required:

Agenda Vote

Description:

The Georgia Department of Transportation (GDOT) has announced that the Governor's office and state legislature included funds in the state's amended fiscal year 2026 budget for Local Road Assistance Administration (LRA). The City of Roswell formula amount for this grant is \$1,221,801.94 and will not require a local match.

LRA funds are available for projects in the same way as the Local Maintenance and Improvement Grant (LMIG) program and may be used for any transportation project that is typically eligible for the state motor fuel sales tax. City of Roswell received the FY 2026 LMIG funds for resurfacing roads. These LRA funds are in addition to the previously received LMIG funds.

Staff recommends the Mayor and Council authorize the Mayor to sign the LRA application to submit to GDOT. Staff also recommends these funds be used to pursue the resurfacing of additional streets and for additional work to be completed along Green St.

Financial Impact:

Once the grant is accepted, the City will accept the state funds in the amount of \$1,221,801.94 from GDOT and a budget amendment will set up the revenues and expenses in Project 91034 (LRA Resurfacing SFY2026).

Comments:

Agenda Item (ID # 10427)

See Attached

STATE OF GEORGIA
COUNTY OF FULTON

May __, 2026

**RESOLUTION TO SUBMIT A 2026 LOCAL ROAD ASSISTANCE ADMINISTRATION
GRANT (LRA) APPLICATION AND TO ACCEPT THE LRA FUNDS IN THE AMOUNT
OF \$1,221,801.94**

WHEREAS, at the regular meeting of the Mayor and Council of Roswell, Georgia, held on the 11th of May, 2026, a motion was made and duly seconded that the City of Roswell, Georgia agrees to submit a 2026 Local Road Assistance Administration Grant (LRA) application for consideration by the Georgia Department of Transportation (GDOT); and

WHEREAS, the City of Roswell is seeking State LRA funding for paving and bridge maintenance; and

WHEREAS, the City of Roswell will accept the funds of \$1,221,801.94 received from the GDOT once the application is accepted; and

WHEREAS, the City of Roswell Finance Department is authorized to do a budget amendment to accept the funds from GDOT once the application is accepted to receive funds; and

WHEREAS, the Roswell Transportation Department will be responsible for the implementation, management, reporting and close-out of the grant project:

NOW, THEREFORE, BE IT RESOLVED by the Council of the City of Roswell that the Mayor of Roswell and/or the City Administrator are authorized to execute this grant application and any subsequent documents necessary to apply and accept for the grant funds, this the ____ of May, 2026.

Attest:

Mary Robichaux, Mayor

Nancy Long, City Clerk
(Seal)

Attachment: Resolution- 2026 LRA Acceptance (2026 GDOT LRA Grant Application)



City of Roswell
Committees of Council
AGENDA ITEM REPORT

ID # - 10374

MEETING DATE: April 28, 2026
DEPARTMENT: Environmental/Public Works
ITEM TYPE: Agenda Vote

Consideration to award a Task Order Chatfield Contracting, Inc. for the Farm Trace Stormwater Construction Project in an amount not to exceed \$380,229.74

Action Required:

Agenda Vote

Description:

The purpose of this project is to replace multiple sections of failed corrugated metal pipes (CMP), catch basins, junction boxes, and a headwall with reinforced concrete pipe (RCP). One pipe will be lined with cured in place pipe (CIPP) instead of full removal and replacement. The failing conveyance system is located within the roadway; however, the roadway will remain passable for residents during construction as this is a single-entry neighborhood.

The City of Roswell sent the scope of work to all stormwater pre-qualified contractors on March 27, 2026. The City received 3 bids which ranged from \$380,229.74 to \$461,290. The City chose the lowest bidder in the amount of \$380,229.74.

Staff recommends awarding the task order to Chatfield Contracting Inc in an amount of \$380,229.74 with a contingency of \$38,023 for unforeseen conditions, for a total budget authorization of \$418,253.

Financial Impact:

Funding in the amount of \$418,253 is available in the Stormwater Fund in Org - 50743200, Object - 541200, Project - 82016 (from Stormwater Master Project List) for stormwater construction projects.

Comments:

See attached.

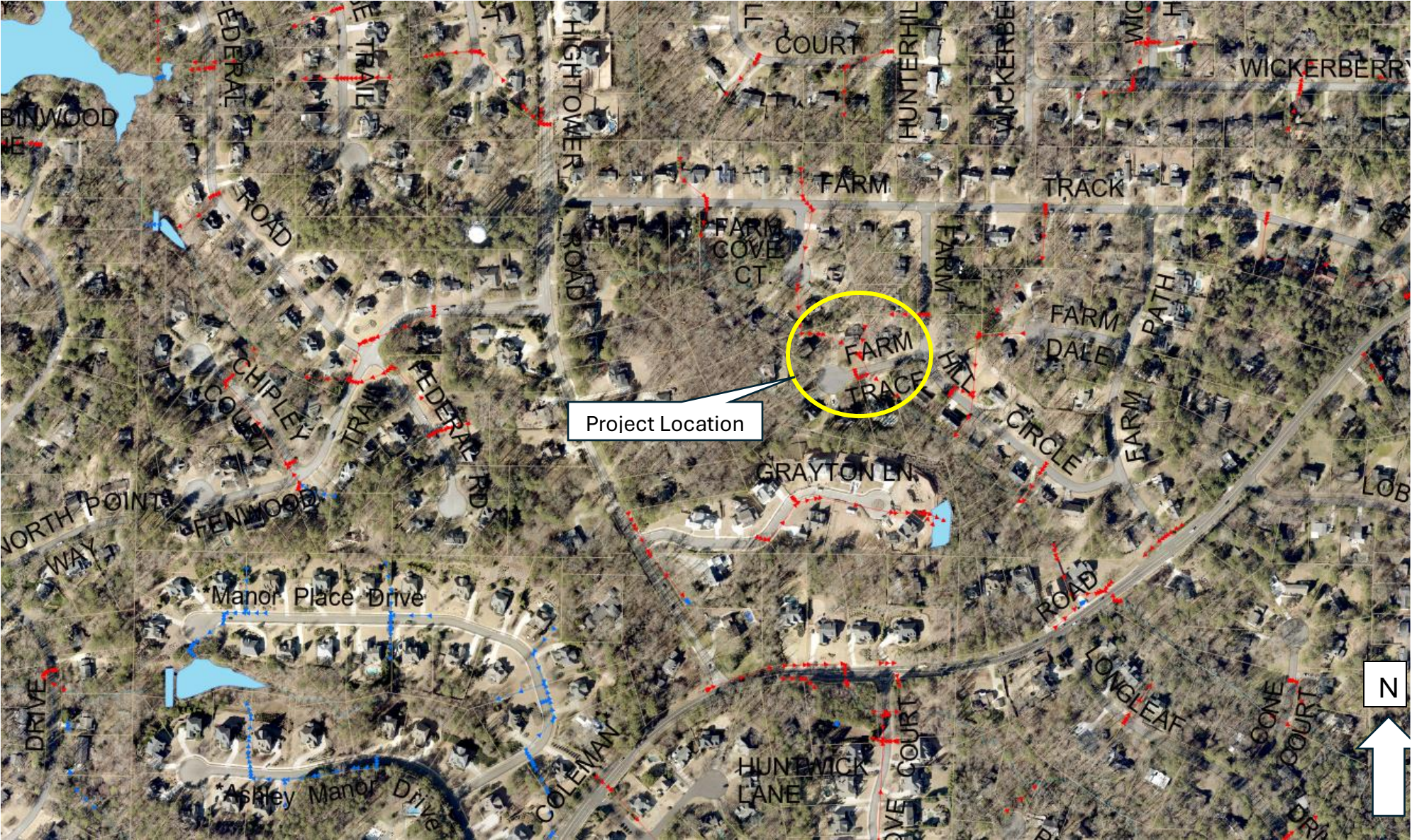

Attachment: Project Figure (Farm Trace Stormwater Project)



City of Roswell
Committees of Council
AGENDA ITEM REPORT

ID # - 10375

MEETING DATE: April 28, 2026
DEPARTMENT: Environmental/Public Works
ITEM TYPE: Agenda Vote

Consideration to award a Task Order with Utility Asset Management for the Holcomb Woods Parkway Stormwater Pipe Lining Project in an amount not to exceed \$88,405

Action Required:

Agenda Vote

Description:

The purpose of this project is to rehabilitate approximately 130 linear feet of 42" corrugated metal pipe (CMP) and approximately 77 linear feet of 18" CMP using either cured in place pipe (CIPP) or structural concrete methods. In addition, the project will repair the existing outfall to prevent further erosion. The failing pipes are located near the roadway; however, the roadway will remain passable for residents during construction.

The City of Roswell sent the scope of work to all pre-qualified stormwater lining contractors on March 27, 2026. The City received 3 responses which ranged from \$88,405 to \$111,671. The City confirmed prices with the bidders, and chose the lowest bidder in the amount of \$88,405.

Staff recommends awarding the task order to Utility Asset Management in the amount of \$88,405 with a contingency of \$8,840 for unforeseen conditions, for a total budget authorization of \$97,245.

Financial Impact:

Funding in the amount of \$97,245 is available in the Stormwater Fund in Org - 50743200, Object - 541200, Project - 82016 (from Stormwater Master Project List) for stormwater construction projects.

Comments:

See attached.



Attachment: Project Figure (Holcomb Woods Parkway Stormwater Project)